

SB5200W915, SB5200W1016, SB5200W1218,
SB5200W1420, & SB5200W1622

Manual # SB5200W_2016

HLA
ATTACHMENTS

OPERATOR'S MANUAL

TABLE OF CONTENTS

Introduction, General Information, Serial Number	2
Owner and Operator and Safety Information	3-6
Definitions of Safety Terms and Symbols, Accident Prevention ..	3
Safety Instructions	4-5
Safety Signs	6
Power Unit Specifications	7
Attachment Specifications	7
Installation Instructions	7
Mounting	7
Hydraulic Instructions	8
Set Up	8
Operation	9
Maintenance	10
Grease Points	10
Service	11
Parts Illustrations	12-18
Endplate	12
Tire Protector	13
Cutting Edge Trip	14-15
Hydraulics	16-17
Frame & Pins	18
Troubleshooting	19-20
Warranty Policy.....	21

HLA Attachments
8082 Rd 129
Listowel, ON N4W 3G8
Canada
1-866-567-4162
sales@horstwelding.com
www.horstwelding.com

INTRODUCTION

Thank you for purchasing your new **HLA 5200 SnowWing Series Snow Blade**. You or any other person, who will be assembling, operating, maintaining or working with this product, are required to read and completely understand the information and instructions contained in this manual. If anyone does not fully understand every part of this manual, please obtain further assistance by contacting the dealer from which this product was purchased or by contacting HLA at the telephone number or address listed on the previous page of this manual. Keep this manual available for reference whenever this product is being handled or used. Provide this manual to any new owners and/or operators.

This manual covers models: **SB5200W1016, SB5200W1218, SB5200W1420, SB5200W1622.**

GENERAL INFORMATION

The purpose of this manual is to assist you in safely assembling, mounting, operating and maintaining your Snow Blade. Read this manual carefully to obtain valuable information and instructions that will help you achieve safe and dependable service. The illustrations and data used in this manual were current at the time of printing, but due to possible engineering and/or production changes, this product may vary slightly in detail. HLA reserves the right to redesign and/or change components as necessary without notification.

Throughout this manual, references may be made to:

Power Unit	The engine-driven machine to which this product must be attached.
Right, Left, Front, Rear	Directions which are determined in relation to the operator of the equipment when seated in the normal operating position.
IMPORTANT	Precautions that must be followed to prevent damage to equipment.
NOTICE	Precautions that must be followed to prevent substandard performance.

SERIAL NUMBER LOCATION

Always refer to the model and serial number when ordering parts or requesting information from your dealer. The serial number plate for this product is located on the top, right of the mouldboard of your Snow Blade (*see diagram on page 6*).

DEFINITION OF SAFETY TERMS AND SYMBOLS

Throughout this manual, the terms **DANGER, WARNING and CAUTION** are used to indicate the degree of hazard to personnel if proper safety procedures are not followed. These words will be used in conjunction with the Safety Alert Symbol: a dark triangle containing a white exclamation mark.

	The Safety Alert Symbol means: - ATTENTION! - BECOME ALERT! - YOUR SAFETY IS INVOLVED!
DANGER	Indicates an imminently hazardous situation, which, if not avoided, WILL result in death or serious injury.
WARNING	Indicates a potentially hazardous situation, which, if not avoided, Could result in death or serious injury.
CAUTION	Indicates a potentially hazardous situation, which, if not avoided, May result in minor or moderate injury; OR May also be used to alert against unsafe practices, which may result in damage to property.

The safety information given in this manual does not replace any safety codes, insurance needs, federal, state and local laws.

ACCIDENTS CAN BE PREVENTED WITH YOUR HELP!

The best safety device is a careful operator. HLA and your dealer ask that YOU be that careful, responsible equipment operator.

Pay attention to the job at hand. Do not let your mind lose concentration on what you are doing. No accident prevention program can be successful without the wholehearted cooperation of the person who is directly responsible for the operation of the equipment.

If accidents are to be prevented (*and accidents can be prevented*), that prevention will come from equipment operators who accept their complete responsibility and anticipate the results of their actions.

The designer, the manufacturer, and the safety engineer all help create a safe product, but their combined efforts can be wiped out with a single careless act by the operator of that product.

Do not attempt to operate this equipment under the influence of drugs or alcohol.

YOU ARE THE KEY TO SAFETY BECAUSE:

YOU are responsible for the SAFE operation and maintenance of YOUR Snow Blade.

YOU are responsible to familiarize yourself, and anyone else who will assemble, operate, maintain, or work around this product, with the safety information contained in this manual.

YOU are responsible to read ALL information contained in this manual to any operators or maintenance personnel who are not fully able to read the written English language. Whether YOU read the manual as written or translate it into another language, YOU must make certain that all operators and maintenance personnel have complete understanding of the full and exact contents of this manual.

YOU can reduce the risk of injury or death by following all safety precautions and by using good safety practices.

SAFETY INSTRUCTIONS

WORK SAFELY - A CAREFUL OPERATOR IS THE BEST INSURANCE AGAINST ACCIDENTS!!

SECTION 1 **WARNING SECTION**



WARNING
Obey all safety instructions listed in this section and throughout this manual. Failure to obey instructions in this section could result in death or serious injury.

BEFORE ATTEMPTING ANY TYPE OF ASSEMBLY, OPERATION, MAINTENANCE OR OTHER WORK ON OR NEAR THIS PRODUCT:

- **READ AND COMPLETELY UNDERSTAND THIS MANUAL.**
- **READ AND COMPLETELY UNDERSTAND THE MANUALS PROVIDED WITH YOUR POWER UNIT, LOADER AND QUICK-ATTACH.**
- Read and understand all safety signs on this product and on your power unit, loader and quick-attach.
- Know all your controls and know how to quickly stop all power unit movements, the Snow Blade movement, and the engine in case of emergency.
- Know and obey all applicable government rules, O.S.H.A regulations, local laws and other professional guidelines for your operation.
- Make sure that anyone who will be assembling, mounting, maintaining, repairing, removing and/or storing this product:
 - Has been instructed in the safe operation of this product and of the power unit and the quick-attach to which this product is attached.
 - Is physically and mentally capable of the safe operation of this type of equipment.
 - Is not under the influence of drugs or alcohol.
 - Is carefully supervised from a safe distance, especially if such person is inexperienced.
 - Wears personal protective equipment (i.e. hardhat, safety glasses, work gloves, protective shoes, respirator, ear protection, etc.)
 - Does not wear loose fitting clothes, loose or uncovered hair or any accessories (jewelry, necktie, scarf, wrist watch, etc.) that can catch and entangle on moving parts.
 - Has annually reviewed all safety instructions.
- Know and follow good work practices when assembling, mounting, maintaining, repairing, removing and storing this product:
 - Work on a level surface in a well lit area.
 - Keep the area clean and dry.
 - Use properly grounded electrical outlets and tools.

- Use the right tool for the job at hand.
- Make sure that your tools are in good condition for performing the desired function.
- When using tools, wear the protective equipment specified by the tool manufacturer (i.e. hardhat, safety glasses, work gloves, protective shoes, etc.).

WHEN YOUR POWER UNIT IS USED DURING ANY TYPE OF ASSEMBLY, OPERATION, MAINTENANCE OR OTHER WORK ON OR NEAR THIS PRODUCT:

- Before leaving the operator's station or before beginning any type of work on this product, lower this product to the ground, apply your power unit's parking brake, stop the engine, remove the starter key, wait for all moving parts to stop and then relieve all pressure in the hydraulic lines. *Refer to your power unit's operator's manual for instructions on how to relieve hydraulic pressure in lines.*
- Know your loader's safe lifting and operating capacity and the weight of this product. See the specifications in this manual for the weight of this product and refer to your power unit's and loader's operator's manuals for safe operating limits. Lift capacity may be reduced if using a quick-attach.
- Never allow anyone, except the operator, to be around the power unit or this product when either is in motion.
- Do not start up unless others are clear of the work area.
- Do not allow riders on this product or the power unit.
- Do not stand or climb on this product when raised.
- Do not place any part of your body under any part of this product unless this product is securely resting on adequate blocking or on the ground.
- Do not use blocking made of concrete blocks, logs, buckets, barrels or any other material that could suddenly collapse or shift positions. Do not use wood or steel blocking that shows any signs of material decay. Do not use wood blocking that is warped, twisted or tapered.
- Never operate controls from the ground. Operate the controls only from the operator's station.
- Never leave the equipment unattended with the engine running or with this product raised on the loader.
- Be aware of the added weight and width of this product. Reduce travel speeds accordingly, especially when traveling over rough ground.
- Never lift this product above (a.) the operator's eye level or (b.) to a height where visibility is obstructed, whichever is lower.
- Keep this product close to the ground and under control when transporting.

SAFETY INSTRUCTIONS
WORK SAFELY - A CAREFUL OPERATOR IS THE BEST INSURANCE AGAINST ACCIDENTS!!

WARNING SECTION [Continued]



WARNING

Obey all safety instructions listed in this section and throughout this manual. Failure to obey instructions in this section could result in death or serious injury.

WHEN DEALING WITH HYDRAULICS DURING ANY TYPE OF ASSEMBLY, OPERATION, MAINTENANCE OR OTHER WORK ON OR NEAR THIS PRODUCT:

- Hydraulic fluid under pressure can penetrate the skin and cause serious injury or death. Hydraulic leaks under pressure may not be visible!
- If any fluid penetrates the skin, GET IMMEDIATE MEDICAL ATTENTION!!
- Wear safety glasses, protective clothing and use a sound piece of cardboard or wood when searching for hydraulic leaks. **DO NOT USE YOUR HANDS!**
- Before connecting or disconnecting hydraulic hoses, read your tractor or power unit's operator's manual for detailed instructions on connecting and disconnecting hydraulic attachments.
- Make certain that all parts meet the specifications for this product when installing or replacing hydraulic hoses or fittings.
- After connecting hydraulic lines:
 - Slowly and carefully raise the loader and cycle the rollback / dump cylinders to check hose clearances and to check for any interference.
 - Operate the hydraulics on this product to check hose clearances and to check for any interference.
 - Make certain that the hoses cannot interfere with or actuate the quick-attach mechanism.
 - Make certain that hoses will not be pinched, or get tangled, in any equipment.
- Do not lock the auxiliary hydraulics of your power unit in the "ON" position.
- Refer to your power unit's operator's manual and this manual for procedures and intervals, then inspect and maintain the entire hydraulic system to insure that the fluid remains clean, that all devices function properly and that there are no fluid leaks.

WHEN MOUNTING THIS PRODUCT TO YOUR POWER UNIT:

- Refer to the operator's manuals of your power unit, your loader and your quick-attach for special or detailed mounting instructions.

- This product should fit onto the quick-attach or loader arms of your power unit the same as the original products that were designed by your loader / quick-attach manufacturer.
- If this product does not fit properly, contact HLA before operating.
- Never place your finger into the mounting plate or loader holes. A slight movement of the power unit or this product could cause serious injury.

BEFORE EACH USE, THOROUGHLY INSPECT THIS PRODUCT AND:

- Make certain that all safety signs are in place and legible. Refer to the safety sign page in this manual for the placement of safety signs for this product.
- Replace all damaged or excessively worn parts and hardware only with genuine HLA parts or with properly rated fasteners, hydraulic hoses or fittings.
- Make certain that all locking pins, latches and connection devices are properly installed and secured.
- Make certain that all protective guards, canopies, doors, etc. are in place and secure.

WHEN OPERATING THIS PRODUCT IN ACCORDANCE WITH DESIGN INTENTIONS:

- Do not exceed 15 MPH/24 KPH when operating.

WHEN ADJUSTING, SERVICING OR REPAIRING THIS PRODUCT:

- Make no modifications to your Snow Blade.
- When making repairs, use only genuine HLA parts or, for fasteners, hydraulic hoses or hydraulic fittings, use only properly rated parts.
- Replacement parts, for parts with safety signs attached, must also have safety sign attached.

Think SAFETY!

Work SAFELY!

SAFETY SIGN LOCATIONS

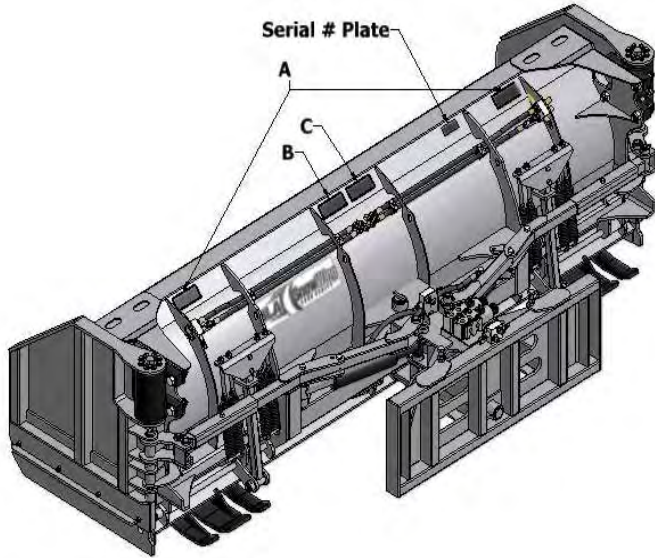

INSTRUCTIONS

- Keep all safety signs clean and legible.
- Replace all missing, illegible or damaged safety signs.
- Replacement parts for parts with safety signs attached must also have safety signs attached.
- Safety signs are available free of charge from your dealer or from HLA.

ITEM	QTY	PART#	DESCRIPTION
A	2	WLPA	Pivoting Attachment
B	1	WLHP	Hydraulics
C	1	WLMA	Manual

PLACEMENT OR REPLACEMENT OF SAFETY SIGNS

1. Clean the area of application with non-flammable solvent, then, wash the same area with soap and water.
2. Allow the surface to fully dry.
3. Remove the backing from the safety sign, exposing the adhesive surface.
4. Apply the safety sign to the position shown in the diagram above and smooth out any bubbles.

Item A



Item B



Item C

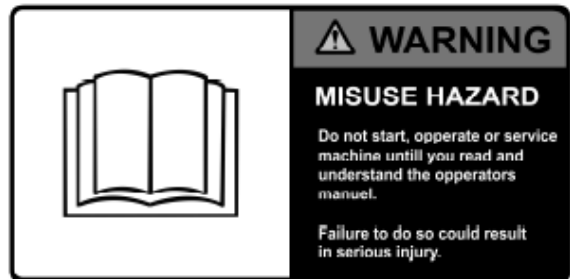

POWER UNIT SPECIFICATIONS

IMPORTANT

Exceeding any of the recommended power unit specifications

- **CAN** result in damage to your power unit and/or this product and
- **WILL** void all HLA warranties.

LOADER DESCRIPTION
110-190 HP
Gross Machine Weight - 40,000 lbs. Max.

ATTACHMENT SPECIFICATIONS

4000W Series

PART #	NAME	APPROX. WEIGHT LBS.	CLEARING WIDTH CLOSED	CLEARING WIDTH OPEN	ROAD CLEARANCE ANGLED INCHES
SB5200W1016	SnowWing 5200 SERIES 10ft	3050	10ft.	16ft	113
SB5200W1218	SnowWing 5200 SERIES 12ft	3320	12ft	18ft	133
SB5200W1420	SnowWing 5200 SERIES 14ft	3585	14ft	20ft	152
SB5200W1622	SnowWing 5200 SERIES 16ft	3855	16ft	22ft	172

SNOW BLADE MOUNTING



SAFETY FIRST!! READ AND UNDERSTAND THE SAFETY INSTRUCTIONS *(pages 3-6 of this manual)* **BEFORE BEGINNING ANY SNOW BLADE MOUNTING.**

1. Place this product on a firm, level surface that is large enough to safely accommodate this product, your power unit and all workers involved in the mounting process.
2. Be sure all connection points are properly secured.
3. Refer to the operator's manual(s) for your power unit, loader and quick-attach and follow the mounting instructions contained therein.

IMPORTANT

Lubricate all grease fittings before connecting this product to your power unit's hydraulic system. Refer to SNOW BLADE MAINTENANCE *(page 10)* and follow instructions

SNOW BLADE HYDRAULIC CONNECTION



SAFETY FIRST!! READ AND UNDERSTAND THE SAFETY INSTRUCTIONS (pages 3-6 of this manual) **BEFORE BEGINNING ANY HYDRAULIC CONNECTION.**

1. You must purchase and install two hydraulic hoses that have fittings permanently attached to each end. These hoses and fittings must meet the following specifications:
 - Inside diameter0.375" (3/8")
 - Maximum operating pressure3,000psi.
 - Hose end fittingsOne hose end must be a female 1/2 NPT fitting. The fitting for the other end can be whatever you determine to be the most beneficial to making the connection to your power unit.
 - LengthYou must make this determination based upon recommendations provided in your power unit's operator's manual. The hoses must be long enough to avoid applying any tension to them (*i.e. stretching*) in all operating positions of this product. Excessive length could cause the hoses to drag on ground, be pinched in equipment, become entangled in moving parts, etc., any of which will shorten life of hoses and could cause injury to operator or others near equipment.
2. Remove all protective plastic caps from hose ends and this product's connection fittings.
3. Ensure the male and female threads, as well as the inside of the hoses, are clean.
4. Make connection to power unit using appropriate method below for your power unit.
 - If your power unit has male or female threads for connecting hydraulic hoses to auxiliary lines, ensure all threads and inside of fittings and hoses are clean; then secure hoses to fittings using torque specified in your power unit's operator's manual.
 - If your power unit has quick-couplers for connecting hydraulic hoses to auxiliary hydraulic lines, you may need to purchase proper quick-coupler fittings which you must install on the free ends of the two hoses. In most cases, the owner's manual for your power unit will describe the exact type of fitting which is needed for your hydraulic coupling system. **BUT** in no case should any fitting have an allowable operating pressure of less than 4,000 psi. Once all quick-coupler fittings are properly installed, the hoses can then be coupled to the power unit's hydraulic valve body or auxiliary hydraulic lines as per the instructions found in your power unit's operator's manual.
5. Carefully raise the loader arm and cycle the tilt cylinders to check hose clearances and to check any interference.
6. Operate hydraulic cylinder(s) on this product to make same checks.
7. Cycle hydraulic cylinder(s) on this product several times fully retracted to fully extended, until all air has been completely removed from cylinder(s).
8. Cycle endplate actuators and force oil through crossover relief valve for 5-8 seconds to ensure all air is out of hydraulic lines.



WARNING

Do not lock the auxiliary hydraulics of your tractor or power unit in the "ON" position. Failure to obey this warning could result in death or serious injury.

NOTICE

When shipped, hydraulic cylinder(s) on this product contained air or air-fluid mixture. Beneath the port(s) in the hydraulic cylinder barrels, are orifices which will restrict exit of that air. Failure to remove all air from the hydraulic cylinder(s) can cause uneven, jerky cylinder movement while the hydraulic controls are being operated, and unwanted cylinder movement when the controls are not being operated.

SNOW BLADE SET UP



SAFETY FIRST!! READ AND UNDERSTAND THE SAFETY INSTRUCTIONS (pages 3-6 of this manual) **BEFORE BEGINNING ANY HYDRAULIC CONNECTION.**

Spring tension is set from factory. If cutting edge trips too easily, simply tighten the tensioner bolts above the springs.

SNOW BLADE OPERATION



SAFETY FIRST!! READ AND UNDERSTAND THE SAFETY INSTRUCTIONS (pages 3-6 of this manual) **BEFORE BEGINNING ANY SNOW BLADE OPERATION.**



WARNING

Failure to obey the following procedures could result in death or serious injury.

- Never lift this product above the operator's eye level OR to a height where visibility is obstructed, whichever is lower.
- Do not exceed 15 miles per hour while operating.

IMPORTANT Striking solid objects hidden in snow OR pushing materials other than snow

- **CAN** result in damage to this product and
- **WILL** void all HLA warranties.

Before any snowfall, inspect site where your Snow Blade is to be used. Locate any obstructions (*i.e. curbs, sidewalks, parking bumpers, pipes, shrubs, fences, etc.*) and any variations in elevation (*i.e. retaining walls, slopes, holes, etc.*), in order to avoid these elements during the snow plowing operation.

Basic Variations on Blade Operating Positions



With the endplates in the full open position, your Snow Blade can be used as a reverse box blade to back drag snow for short distances.

IMPORTANT Do not operate in position shown below.
Leading wing must always be in forward position.
If wing is back against stop and hits a solid object, it will bend wing or damage actuator.

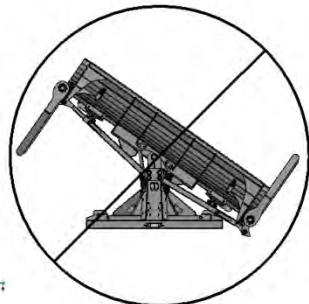

SNOW BLADE MAINTENANCE

Regular maintenance is the key to long equipment life and safe operation. It is very important that these maintenance functions be performed as described below.



SAFETY FIRST!! READ AND UNDERSTAND THE SAFETY INSTRUCTIONS (pages 3-6 of this manual) **BEFORE BEGINNING ANY SNOW BLADE MAINTENANCE.**

BEFORE FIRST USE

- Inspect the attachment for shipping damage. If damage does exist, do not operate until the damaged parts have been replaced or repaired.

BEFORE EACH USE

- Make certain all nuts and bolts are in place and properly tightened.
- Make certain all other fasteners are in place and are performing their specified function.
- Make certain all hydraulic fittings are tightened and that there are no leaks in any fittings or hoses.
- Make certain all safety signs are in place, are clean and are legible.
SEE THE SAFETY SIGN SECTION (page 6)
- Replace any damaged parts and excessively worn parts.

AFTER EVERY 10 HOURS OF OPERATION

- Grease all grease fittings (refer to diagram below).

GREASE POINTS

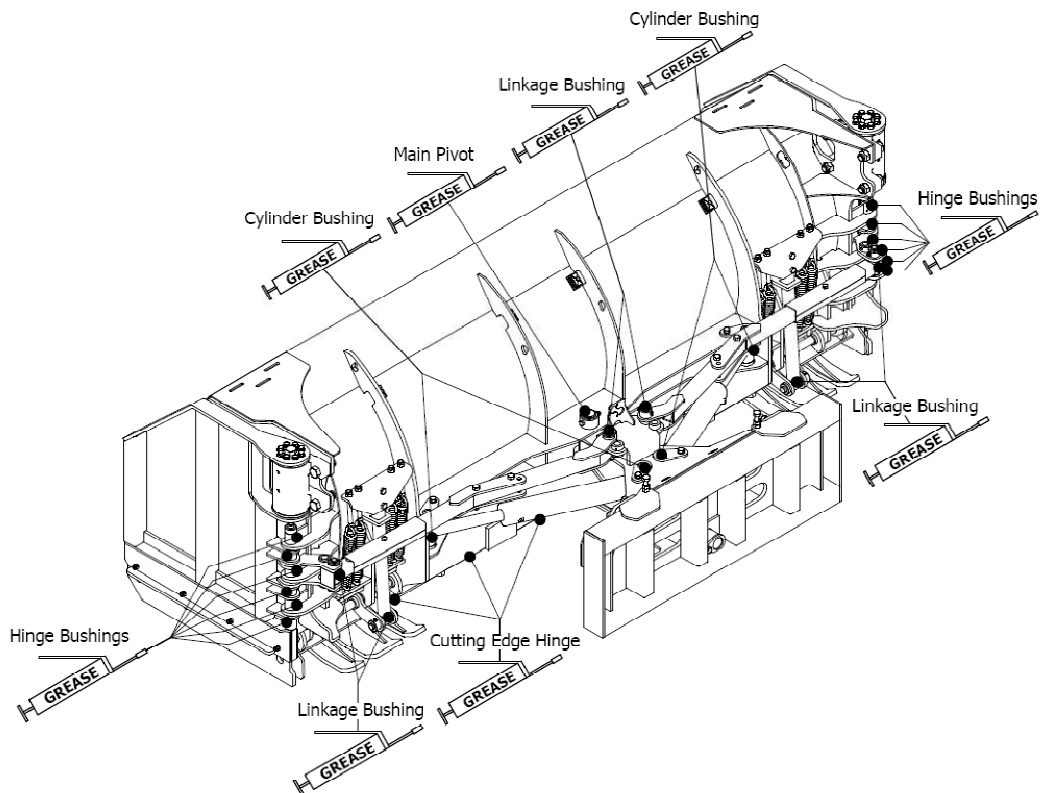

SNOW BLADE SERVICE



SAFETY FIRST!! READ AND UNDERSTAND THE SAFETY INSTRUCTIONS (*pages 3-6 of this manual*) **BEFORE BEGINNING ANY SNOW BLADE SERVICE.**



WARNING

Hydraulic fluid under pressure can penetrate skin, resulting in serious injury or death. Always relieve hydraulic pressure before disconnecting lines.

REPLACEMENT OF WEAR EDGE

1. Park power unit on level surface with this product properly attached.
2. Place power unit's transmission in "Park" and engage the parking brake.
3. Lower this product onto blocking positioned immediately behind moldboard. This blocking must be of sufficient height to hold wear edge approximately 6" to 8" above the level surface.
4. Shut off power unit's engine, set parking brake, remove starter key, wait for all moving parts to come to a stop and relieve hydraulic pressure. *Refer to your power unit's manual for instruction on how to relieve hydraulic pressure in lines.*
5. Loosen and remove nuts on all wear edge bolts except the bolts on each end of wear edge.
6. While holding up end of wear edge, remove nut and bolt from that end and allow it to pivot down to the level surface.
7. Repeat step 6 for other end of wear edge.
8. Properly dispose of wear edge and all bolts and nuts.
9. Reinstall new wear edge by reversing procedures in steps 7 through 5 and tightening the nuts to 75 ft. lbs.

2016 - current
SB5200 SnowWing Endplate

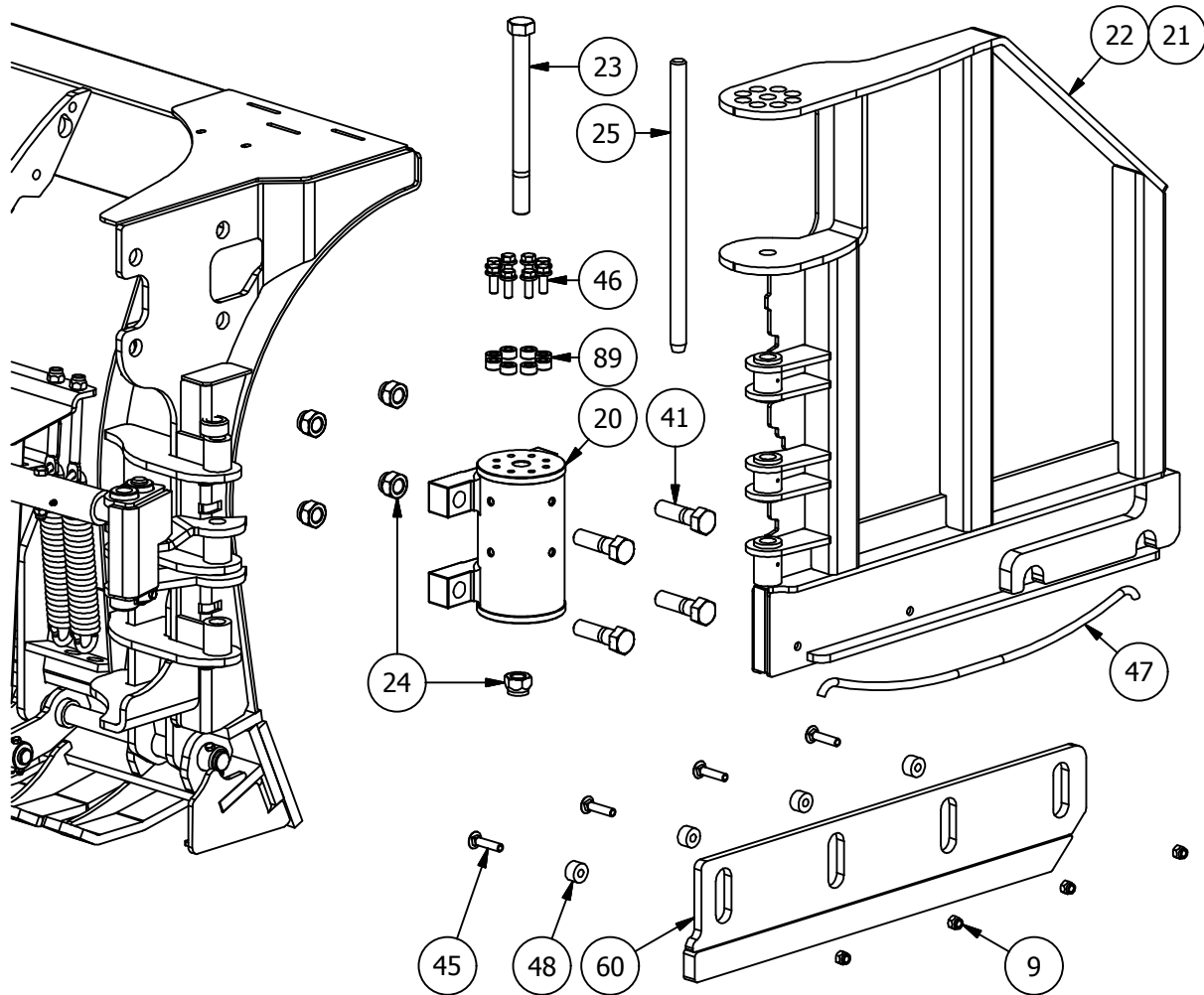

Parts List			
ITEM	QTY	PART NUMBER	DESCRIPTION
9	15	11-2068	1/2" Lock Nut
20	2	LA-L2015E	L20-15 180° Rotator
21	1	LP-100110	Left 180° Endplate Assembly
22	1	LP-100119	180° Endplate Assembly
23	2	112086	1" x 12" gr8 Hex Bolt - UNC
24	10	11-1562	1" Lock Nut
25	2	LP-100121	Endplate Pivot Pin
41	8	11-1561	1" x 3-1/2" Hex Head Bolt
45	8	11-1568	1/2" x 2-1/4" Carriage Bolt
46	16	11-1569	1/2 - 13 x 1-1/4 Hex Flange Screw L9
47	2	LP-100032	SB4000W Endplate Float Spring
48	8	LA-SB1139	SB4000 Endplate Wearbar Spacer
60	2	LP-101266	Endplate Cutting Edge Assembly
89	16	LP-101611	SB42W & SB52W Actuator Bolt Bushing

2016 - current

SB5200 SnowWing Tire Protector

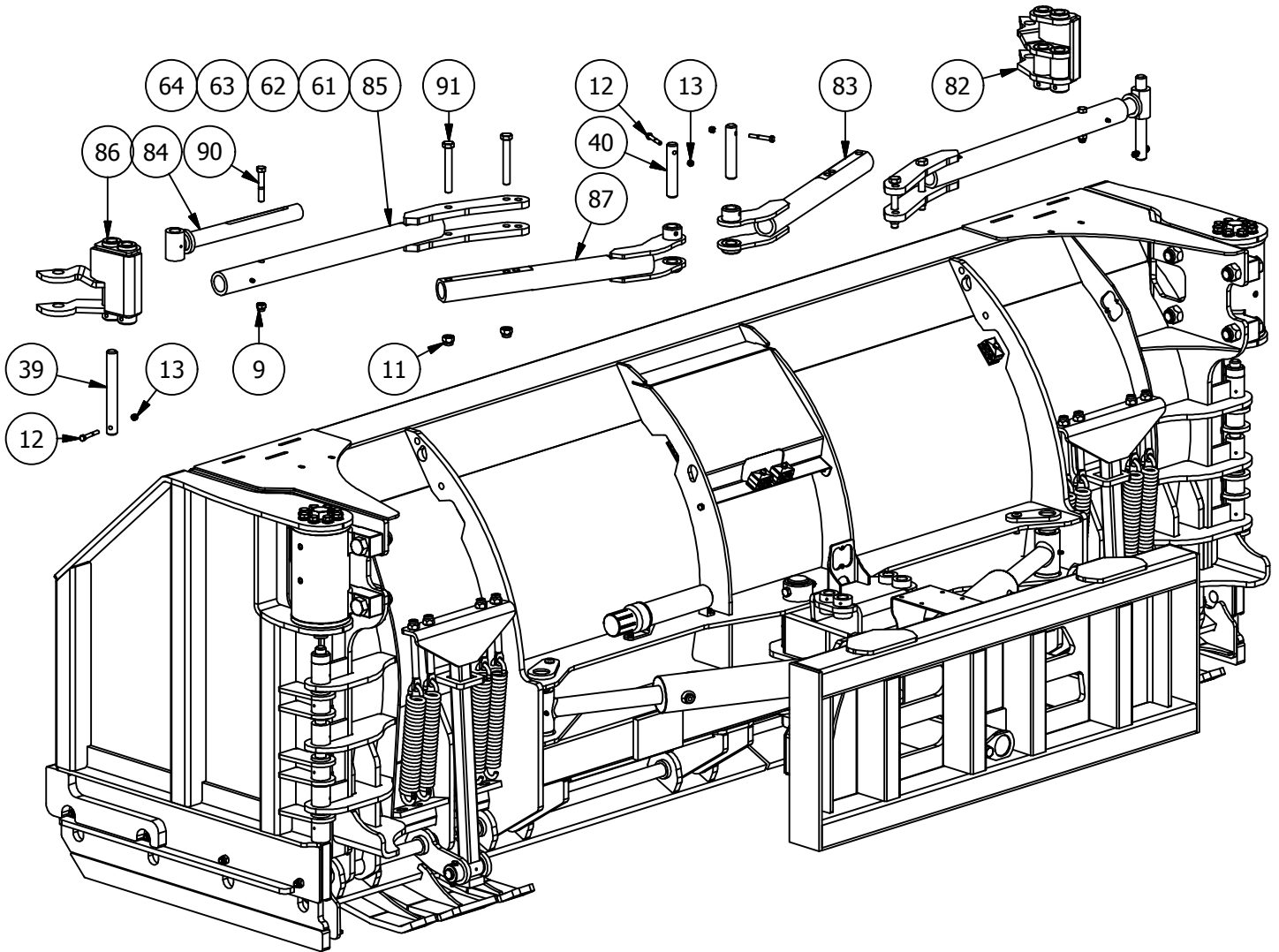

Parts List				Parts List			
ITE	QT	PART NUM	DESCRIPTION	ITE	QT	PART NUM	DESCRIPTION
9	15	11-2068	1/2" Lock Nut	82	1	LP-101678	SB4200W Right Top Endplate Stop Assembly
11	28	11-1026	5/8" Lock Nut				
12	8	11-2079	5/16" x 2 1/4" Bolt	83	1	LP-101612	HD Tire Protector Inner Tube Assembly
13	12	11-2078	5/16" Lock Nut				
39	2	LP-100031	1" x 8-1/4" Pin	84	2	LP-101614	HD Tire Protector End Tube Assembly
40	2	LA-SB1081	1" x 5-1/4" Pin	85	2	LP-101618	10' HD Tire Protector Outer Tube Assembly
61	1	LP-100104	9' Tire Protector Outer Tube Assembly				
62	1	LP-100137	16' Tire Protector Outer Tube Assembly	86	1	LP-101677	SB4200W Left Top Endplate Stop Assembly
63	1	LP-100106	14' Tire Protector Outer Tube Assembly	87	1	LP-101613	HD Left Tire Protector Inner Tube Assembly
64	1	LP-100105	12' Tire Protector Outer Tube Assembly	90	2	11-2071	1/2" x 3" Bolt
				91	4	11-1025	5/8 x 4 1/2 Hex Bolt & Locknut

2016 - current

SB5200 SnowWing Cutting Edge Trip

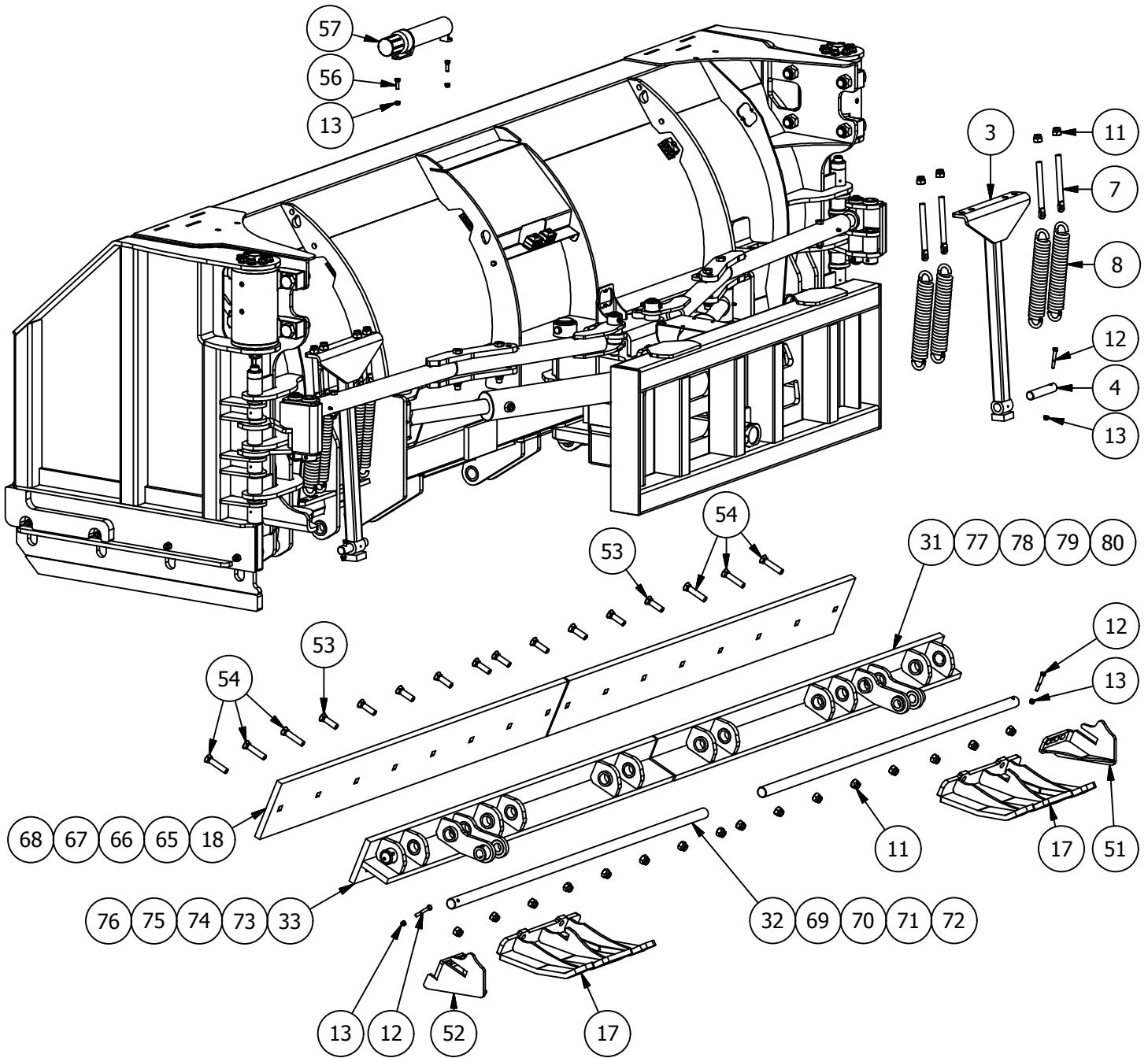

2016 - current

SB5200 SnowWing Cutting Edge Trip



Parts List			
ITEM	QTY	PART NUMBER	DESCRIPTION
3	2	LA-SB1074	SB4000 & SB5000 Trip Linkage Assembly
4	2	LA-SB1118	SB5000 Trip Linkage Pin (1" x 5 1/4")
7	8	11-1516	5/8" x 7" Eye Bolt
8	8	11-1515	3/8" Coil x 1-7/8" OD x 12" Extension Spring
11	28	11-1026	5/8" Lock Nut
12	8	11-2079	5/16" x 2 1/4" Bolt
13	12	11-2078	5/16" Lock Nut
17	2	LA-SB1075	Cuttingedge Bolt-on Skid Shoe Assembly
18	2	LA-SB1088	60" Cutting Edge (3/4" x 8" x 60") c/w Bolts & Nuts
31	1	LP-100111	10' SnowWing Right Cutting Edge Assembly
32	2	LP-100266	SB5000 10' Cutting Edge Pin (1 1/4" x 53")
33	1	LP-100112	10' SnowWing Left Cutting Edge Assembly
51	1	LP-101036	Cuttingedge T Endcap Assembly
52	1	LP-101037	Cuttingedge T Endcap Assembly (Left)
53	10	112083	5/8" x 2-1/4" Countersunk Square Neck Scraper Dome Bolt
54	6	112066	5/8" x 3" Countersunk Square Neck Scraper Dome Bolt
56	4	11-1946	5/16" x 1" bolt
57	1	11-2008	Manual Holder HD
65	1	LA-SB1087	54" Cutting Edge (3/4" x 8" x 54") c/w Bolts & Nuts
66	1	LA-SB1110	96" Cutting Edge (3/4" x 8" x 96") c/w Bolts & Nuts
67	1	LA-SB1089	72" Cutting Edge (3/4" x 8" x 72") c/w Bolts & Nuts
68	1	LA-SB1109	84" Cutting Edge (3/4" x 8" x 84") c/w Bolts & Nuts
69	1	LP-100113	SB5000 9' Cutting Edge Pin (1 1/4" x 53")
70	1	LA-SB1113	SB5000 16' Cutting Edge Pin (1 1/4" x 53")
71	1	LA-SB1112	SB5000 14' Cutting Edge Pin (1 1/4" x 53")
72	1	LA-SB1111	SB5000 12' Cutting Edge Pin (1 1/4" x 53")
73	1	LP-101165	9' SnowWing Left Cutting Edge Assembly
74	1	LP-100117	16' SnowWing Left Cutting Edge Assembly
75	1	LP-100133	14' SnowWing Left Cutting Edge Assembly
76	1	LP-100115	12' SnowWing Left Cutting Edge Assembly
77	1	LP-101166	9' SnowWing Right Cutting Edge Assembly
78	1	LP-100116	16' SnowWing Right Cutting Edge Assembly
79	1	LP-100132	14' SnowWing Right Cutting Edge Assembly
80	1	LP-100114	12' SnowWing Right Cutting Edge Assembly

2016 - current
Hydraulic Components
(Double Selector Valve)

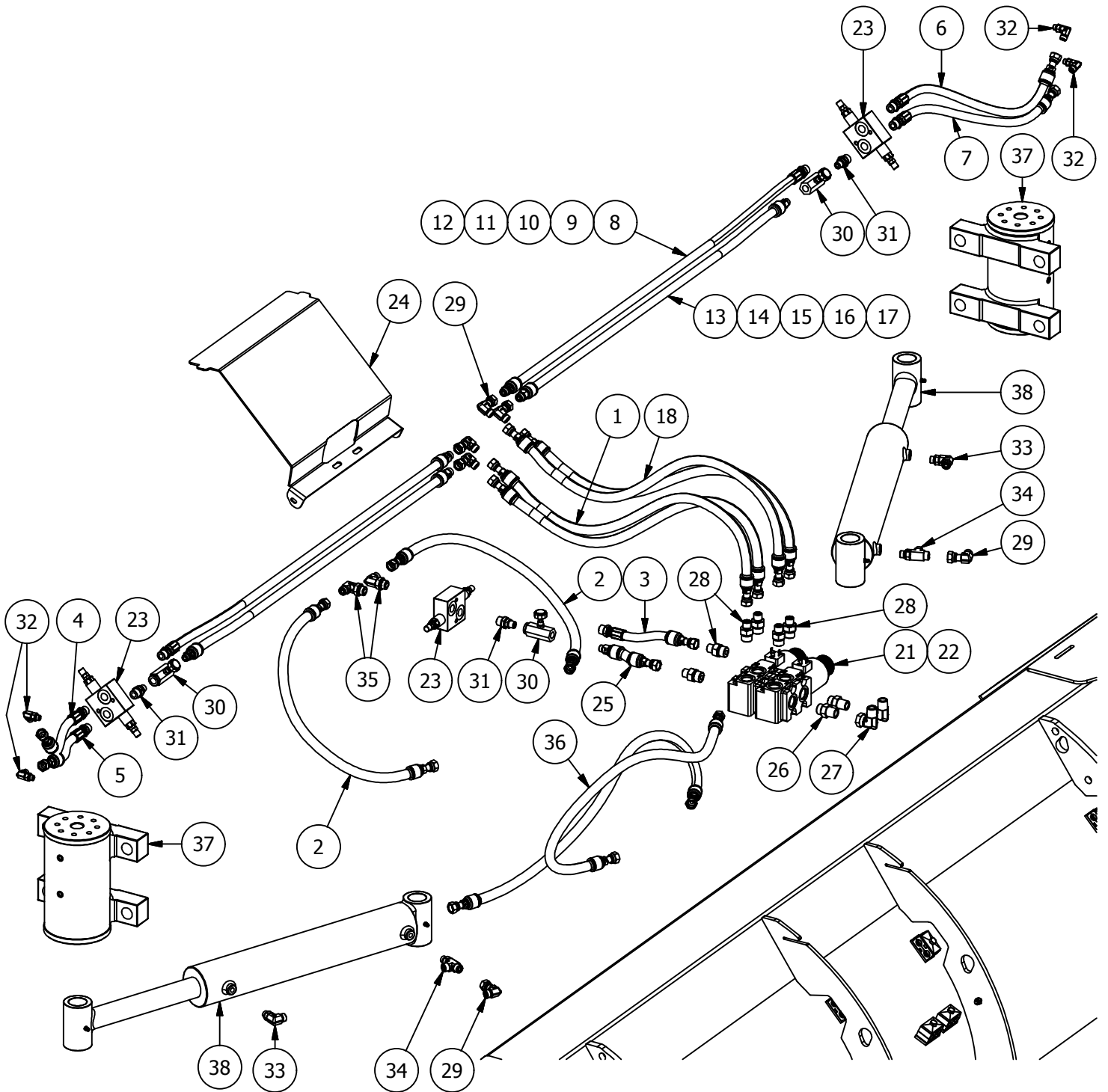

2016 - current
Hydraulic Components
 (Double Selector Valve)



Parts List			
ITEM	QTY	PART NUMBER	DESCRIPTION
1	2	HH-100645	SB5200W Front Selector Valve To Wing Hose (ORFS Fittings)
2	2	HH-100642	SB5200W Relief Valve To Angle Cyl Hose (ORFS Fittings)
3	1	HH-100643	SB5200W Selector Valve To Relief Valve Hose (ORFS Fittings)
4	1	HH-100640	SB5200W Top LH Actuator Hose (ORFS Fittings)
5	1	HH-100641	SB5200W Bottom LH Actuator Hose (ORFS Fittings)
6	1	HH-100638	SB5200W Top RH Actuator Hose (ORFS Fittings)
7	1	HH-100639	SB5200W Bottom RH Actuator Hose (ORFS Fittings)
8	2	HH-100648	SB5200W1016 Wing Top Hose (ORFS Fittings)
9	1	HH-100586	SB5000W915 Wing Top Hose (ORFS Fittings)
10	1	HH-100580	SB5000W1218 Wing Top Hose (ORFS Fittings)
11	1	HH-100582	SB5000W1420 Wing Top Hose (ORFS Fittings)
12	1	HH-100584	SB5000W1622 Wing Top Hose (ORFS Fittings)
13	2	HH-100647	SB5200W1016 Wing Bottom Hose (ORFS Fittings)
14	1	HH-100587	SB5000W915 Wing Bottom Hose (ORFS Fittings)
15	1	HH-100581	SB5000W1218 Wing Bottom Hose (ORFS Fittings)
16	1	HH-100583	SB5000W1420 Wing Bottom Hose (ORFS Fittings)
17	1	HH-100585	SB5000W1622 Wing Bottom Hose (ORFS Fittings)
18	2	HH-100646	SB5200W Rear Selector Valve To Wing Hose (ORFS Fittings)
19	6	11-2075	1/4" x 2" Bolt
20	6	11-2074	1/4" Lock Nut
21	1	DEDV612	12 Volt Double Electric Selector Valve Only (Less Wiring)
22	1	DEDV624	24 Volt Double Electric Selector Valve Only (Less Wiring)
23	3	LA-SB2000RV	Crossover Relief Valve
24	1	LP-100962	SB5200W Centre Hose Mount
25	1	HH-100644	SB5200W Selector Valve To Needle Valve Hose (ORFS Fittings)
26	2	HF-64011008	5/8" MORB - 1/2" MNPT Adapter
27	2	HF-15010808	90° Elbow 1/2 M-NPT - 1/2 F-NPT Swivel
28	6	FS6400-0610	11/16 M-ORFS - 7/8 M-ORB Adapter
29	6	FS6500-0606	11/16 M-ORFS - 11/16 F-ORFS 90° Elbow Adapter
30	3	11-2793	3/8" F-ORB 2 Way Needle Valve
31	3	HF-64070608	06 M-ORB / 08 M-ORB Adapter
32	4	FS6801-0604	11/16 M-ORFS - 7/16 M-ORB 90° Elbow Adapter
33	2	FS6801-0606	11/16 M-ORFS - 9/16 M-ORB 90° Elbow Adapter
34	2	FS6804-060606	9/16 M-ORB - 11/16 M-ORFS - 11/16 M-ORFS Tee Adapter
35	2	FS6801-0608	11/16 M-ORFS - 3/4 M-ORB 90° Elbow Adapter
36	2	HH-100636	SB5000 Angle Cyl Connector Hose (ORFS Fittings)
37	2	11-2309	L20-15 180 Degree Rotator
38	2	LA-CYL316	3" x 16" Cross Tube Welded Cylinder

2016 - current

SB5200 SnowWing Frame & Pins

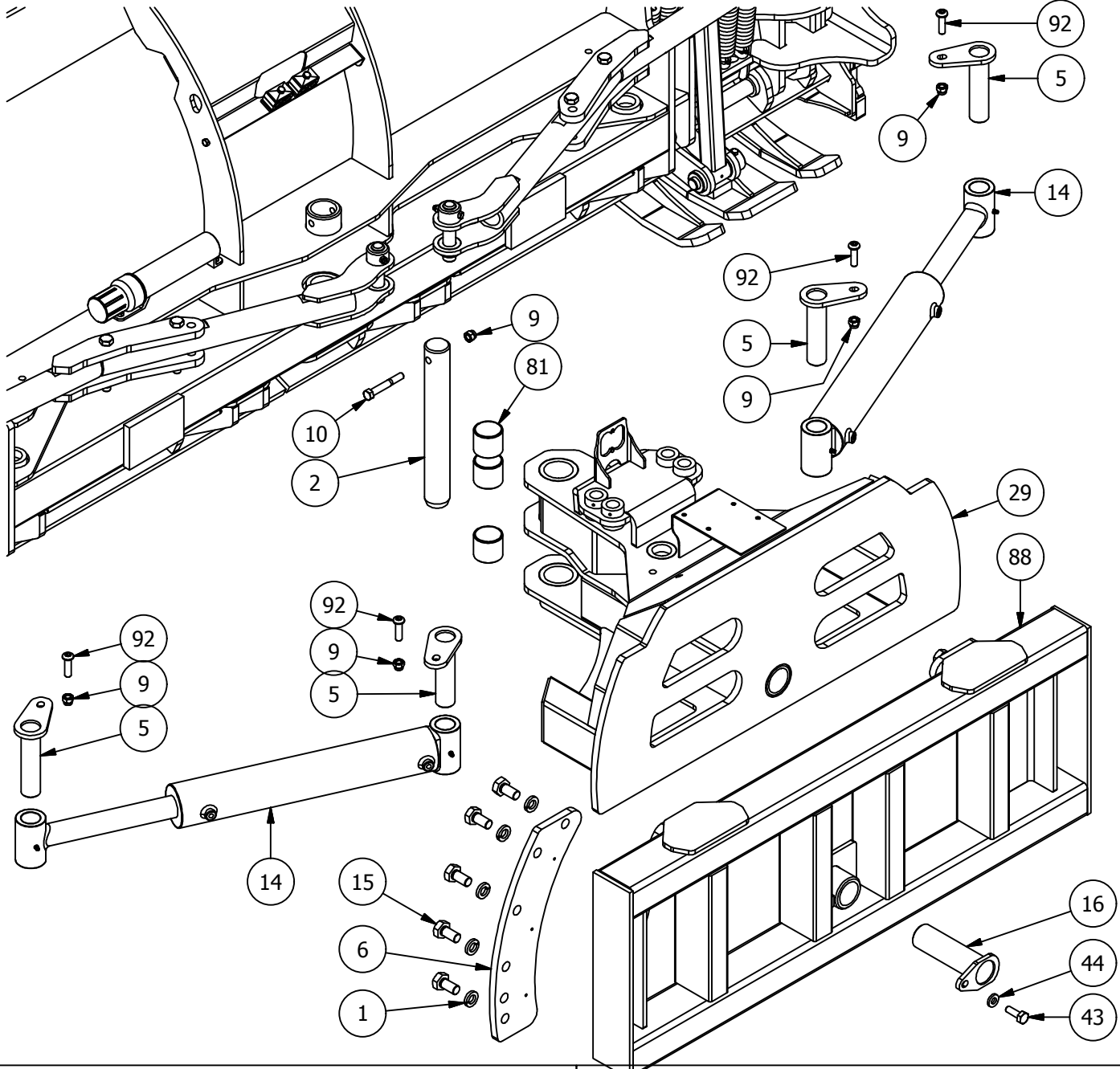

Parts List				Parts List			
ITEM	QTY	PART NUMBER	DESCRIPTION	ITEM	QTY	PART NUMBER	DESCRIPTION
1	10	11-2291	3/4" Lock Washer	16	1	LA-SB1117	SB5000 Frame Pin Assembly
2	1	LA-SB1084	SB5000 Blade Main Pivot Pin (2" x 15")	29	1	LP-101679	SB5200W Wingblade Clevis Weldment
5	4	LA-SB1107	SB5000 Cylinder Pin Assembly	43	1	111802	1/2" x 1-1/2" Hex Bolt
6	2	LA-SB1086	SB5000 Subframe Retainer Plate	44	1	11-1579	1/2" Flat Washer
9	15	11-2068	1/2" Lock Nut	81	1	11-2752	2-1/4" x 2" x 2" Iglide Q Sleeve
10	1	11-2072	1/2" x 3 1/2" Bolt	88	1	LA-SB1100	SB5000 Frame Assembly Less Attachment
14	2	LA-CYL316	3" x 16" Cross Tube Welded Cylinder	92	4	11-2795	1/2" X 1-3/4" Button Head Socket Cap Bolt
15	10	11-2076	3/4-16 x 1 1/2" Fine Thread Bolt				

Banked Diverter Valve Plumbing & Electrical Directions

AUXILARY OUTPUT (3rd FUNCTION)
Activated when valve is switched **on**.

AUXILARY OUTPUT (2nd FUNCTION)
Activated when valve is switched **on**.

14 ga.4 wire.
(Use only 3 wires)

Ground
Valve #1
Valve #2

DEFAULT OUTPUT LINES
(B1 & B2)
Automatically on when
valve is switched **off**.

Ground
Please discard
terminal protector.

ON OFF ON
To Valve #2
To 12 volt
+ ignition.
To Valve #1

Ground Terminal #2
Live Terminal #1

Do not use middle terminal.

Standard "switch bracket" to be
mounted in operators station.
(Mount on joy stick if possible)

All hydraulic ports on diverter valve are #10 ORB.

INPUT LINES
(from remotes)
(A1 & A2)

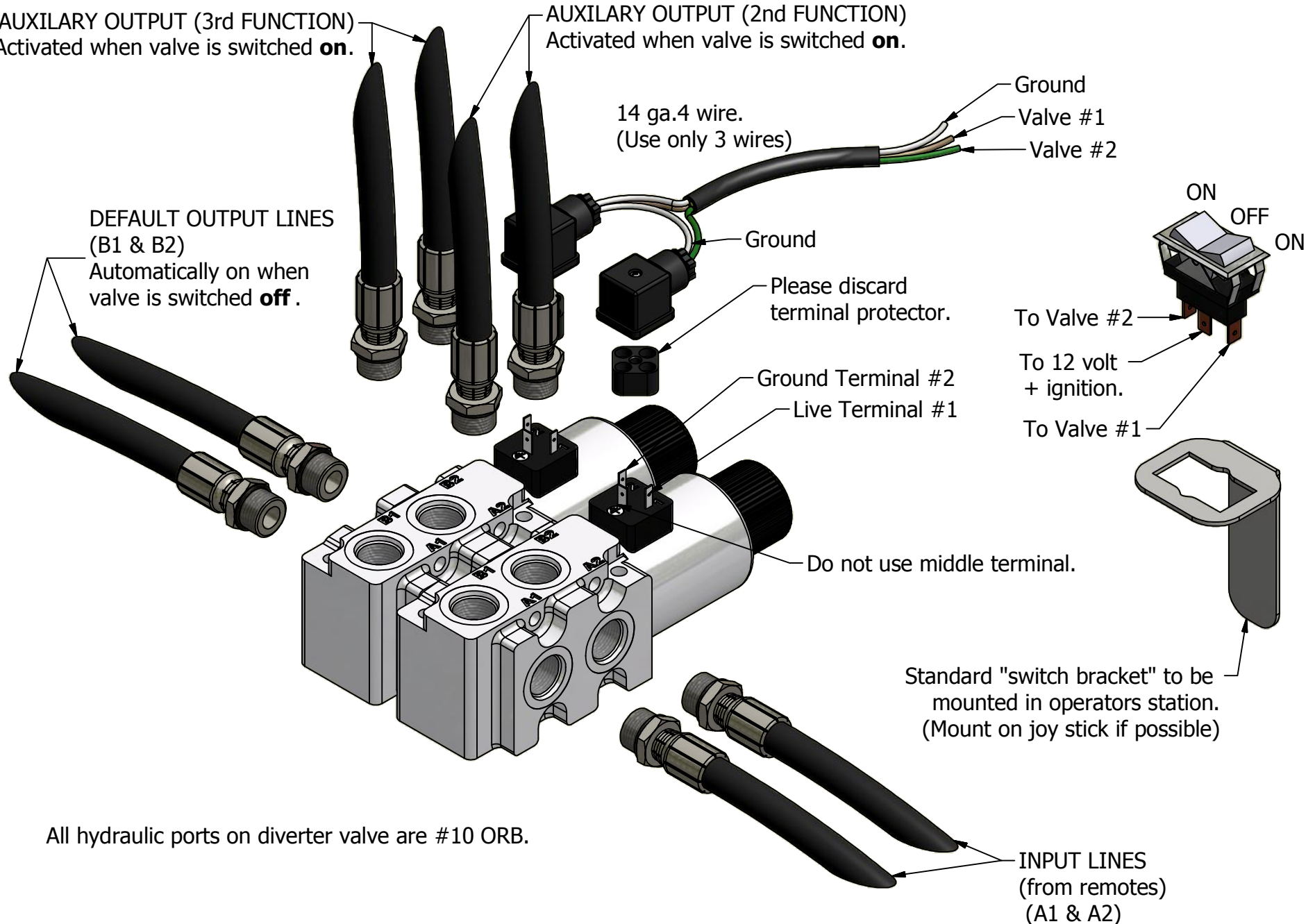

Double Diverter Valve Electrical Diagram

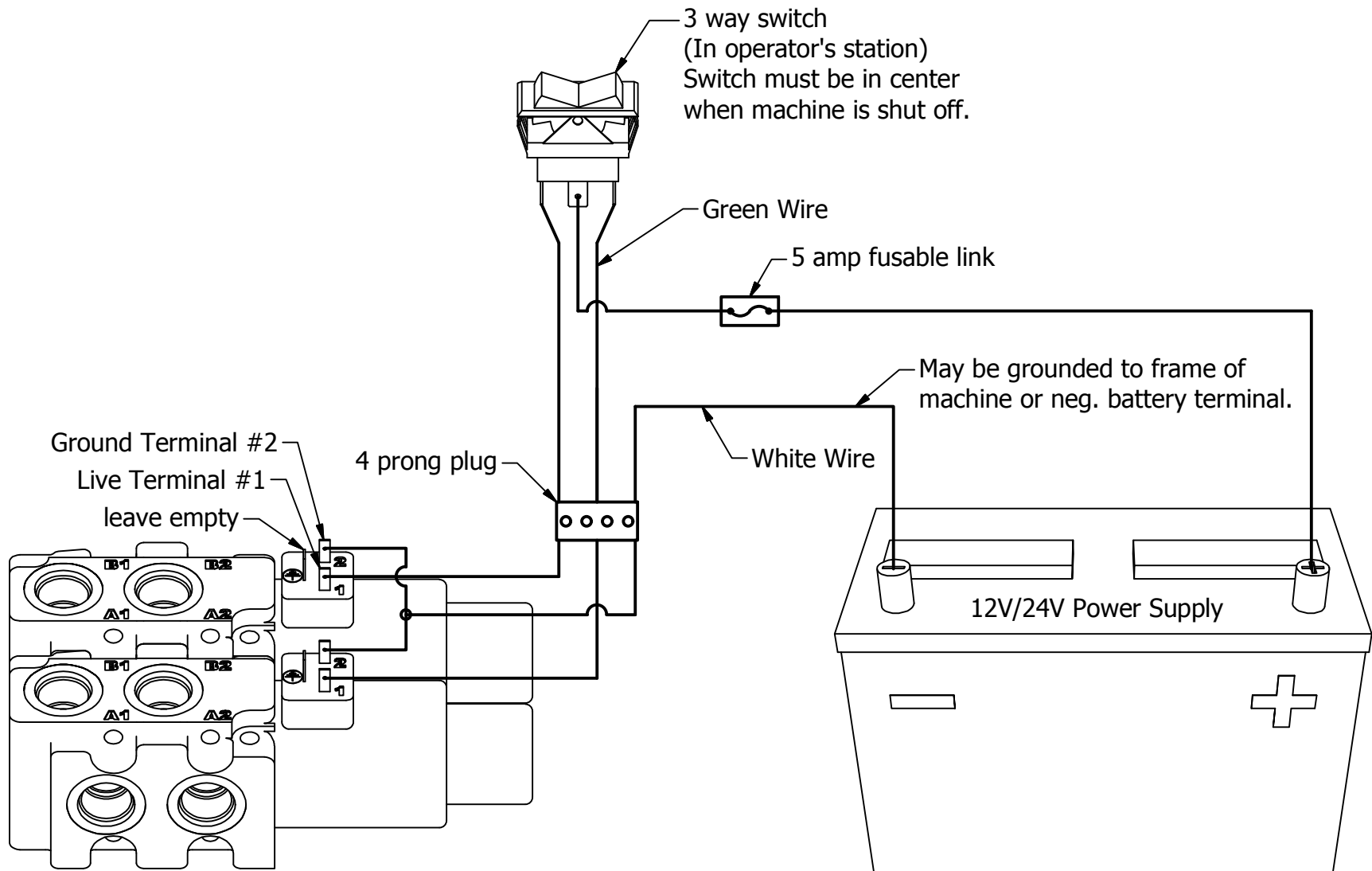

12V/24V diverter valve located on implement
(power supply must match the required
voltage stamped on the solenoid)

Single Diverter Valve Plumbing & Electrical Directions

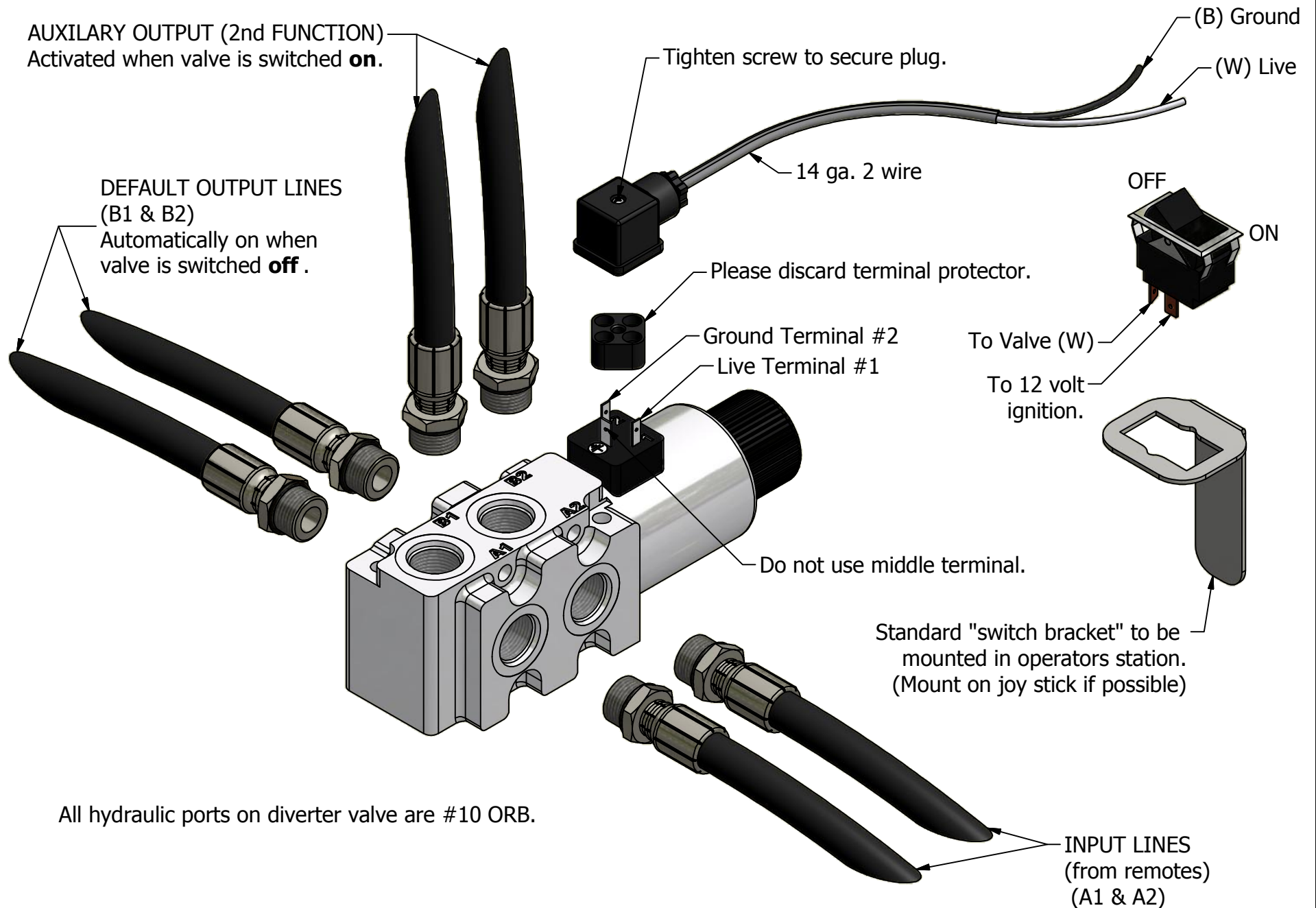

Diverter Valve Electrical Diagram

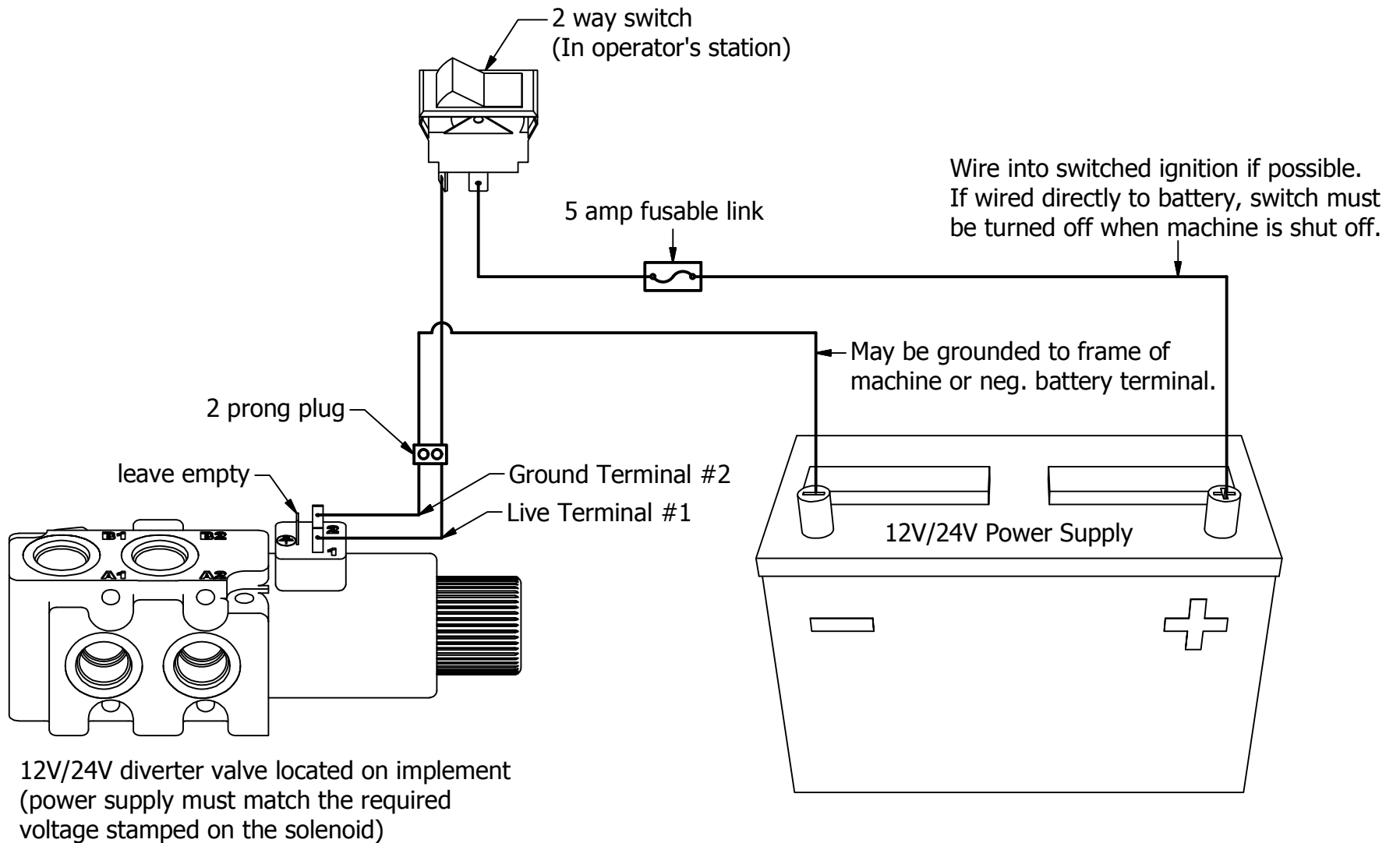

TROUBLESHOOTING

PROBLEM	POSSIBLE CAUSE	SOLUTION
Angle cylinders malfunctioning	Low hydraulic fluid level	Check and replenish hydraulic fluid
	Improper hose hookup	Check and correct hydraulic hose connections
	Broken hydraulic line	Check for leaks and replace line
	Bent piston rod	Replace or repair cylinder
	Quick disconnect coupler(s) are not connected or "Flow Check"	Check coupler connections Replace coupler(s) if necessary
	Hydraulic hose blockage	Check for evidence of damage to hoses that would block flow of oil between cylinders and control valve
	Hydraulic fluid leaking past packing or seals	Replace packing or seals
Cylinders operate in wrong direction relative to control valve lever position	Hydraulic hoses connected incorrectly	Correct hydraulic hose connections
Aeration of hydraulic fluid <i>(generally indicated by foamy appearance of fluid).</i>	Low hydraulic fluid level	Check and refill hydraulic system to proper level
	Hydraulic fluid foaming due to improper hydraulic oil usage	Refer to Power Unit's manual and replace hydraulic oil using recommended hydraulic oil
Hydraulic oil heating	Dirty oil	Drain and refill oil, replace filter
	Partially plugged inlet filter	Clean filter element
	Oil too light in hot weather	Use recommended oil
	Damaged oil lines	Replace oil lines
External hydraulic fluid leakage	Cylinder seals damaged	Repair cylinder
	Broken oil lines	Replace hose and check for leaks
	Loose hydraulic connection	Tighten loose connections
Hydraulic pump capacity inadequate	Cold hydraulic fluid	Allow hydraulic fluid to warm up to operating temperature
	Engine R.P.M. too slow	Increase engine R.P.M.
	Low hydraulic fluid supply	Refer to Power Unit's manual for service recommendations
	Hydraulic hose restriction	Check for evidence of restriction in hydraulic hoses
Wing rotation speed too fast or too slow	Hydraulic hose blockage	Check for evidence of damage to hoses that would block flow of oil between cylinders and control valve
	Needle valve setting out of adjustment	Turn needle clockwise to slow and counter clockwise to speed up

TROUBLESHOOTING (CONT.)

PROBLEM	POSSIBLE CAUSE	SOLUTION
Cutting edge digging into surface	Soft surface or blade tipped forward too far	Tip blade back to ride on skid shoes
Premature wear out of cutting edge	Excessive down pressure on loader hydraulics	Set hydraulics in "float" position if possible
	Blade tipped ahead too far	Tip blade back to ride on skid shoes
Cutting edge trips too easily	Tension too loose on trip springs	Increase tension on trip springs
Thin film of oil/fluid on body of actuator	Normal occurrence	No action required
Green lubricating grease between body and endcaps	Normal occurrence in first 10 hours of use (<i>factory packing grease</i>)	No action required
Endplates hitting front tires on power unit	Tire protector not set properly for power unit width	Set tire protector to proper setting to push endplate out more



Horst Welding Warranty Policy

All equipment is sold subject to mutual agreement that it is warranted by the company to be free from defects of material and workmanship. But the company shall not be liable for special, indirect, or consequential damages of any kind under this contract or otherwise. The company's liability shall be limited exclusively to replacing or repairing without charge, at its factory or elsewhere, at its discretion, any material or workmanship defects that become apparent within one year from the date on which the equipment was purchased. The company shall have no liability for related damages of any kind. The buyer by the acceptance of the equipment will assume all liability for any damages that may result from the use or misuse by his employees or others.

Distributor/dealer must notify Horst Welding of the defect by phone, fax or email. Recommended repairs and cost are to be discussed with, and agreed on, by an authorized Horst Welding representative. Repair and labor (*at an agreed rate*) will be performed by a dealer for Horst Welding or a repair shop designated by Horst Welding.

All claims **must** be discussed with a representative of Horst Welding prior to any repairs or warranty will be **void**.

All claims must be accompanied by a photograph of the defective product.

All defective products must be returned to Horst Welding in Listowel, Ontario unless directed otherwise by a representative of Horst Welding.

Horst Welding Warranty will not apply to:

- Product that in the judgment of Horst Welding has been misused by the user.
- Product not sold or manufactured by Horst Welding.
- Alterations or repairs not authorized by a representative of Horst Welding.